

Voltage Controlled Panner

© G. Forrest Cook 1994

cook@stout.atd.ucar.edu

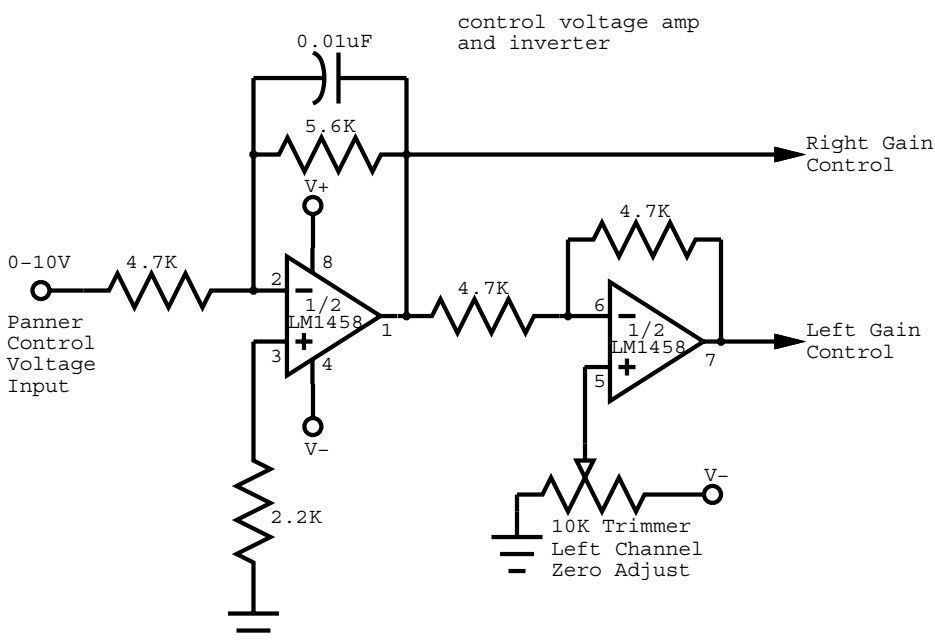
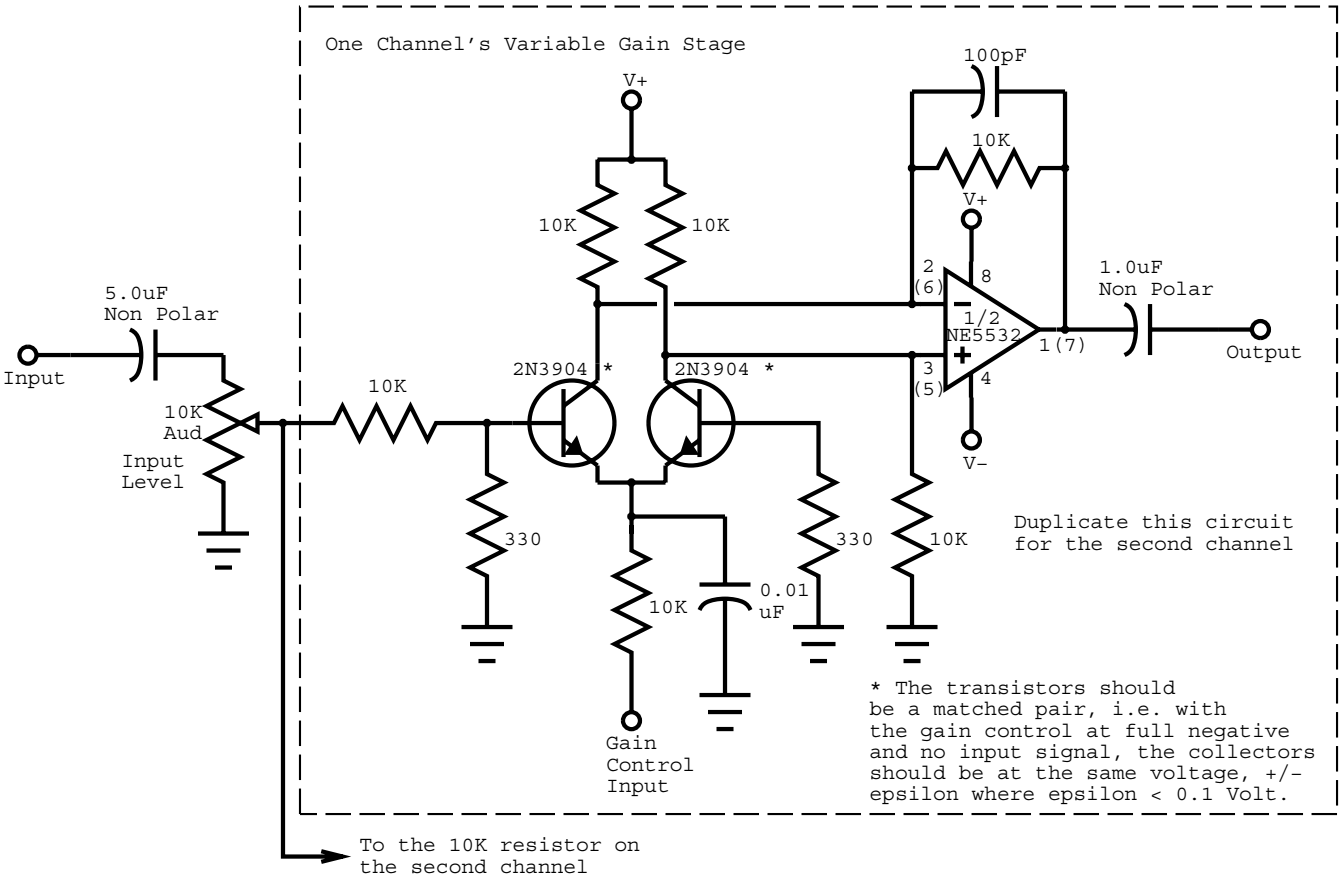

The power supply is +/- 15 VDC

power supply filter

